



CSCART

CONE STORAGE CART

Features:

- Combination Cone Or Scooter Storage Cart
- Can Hold Up To 30 Scooters, Eighty C12 Cones or Fifty C18 Cones
- Constructed From 1" Galvanized Steel, Sits on 8" Diameter Rubber Wheels
- Assembly Required
- 32"l X 16"w X 48"h
- Silver

Instructions:

Effortlessly move and store your cones or scooters with the Champion Sports Cone and Scooter Cart.

1. Attach the crossbar handle to the base. Figure 1
2. Using the center bar nuts & bolts, attach the center bar to the handle/base. Figure 2
3. Using the wheel nuts & bolts, attach the wheels to the cart. Figure 3



Figure 1

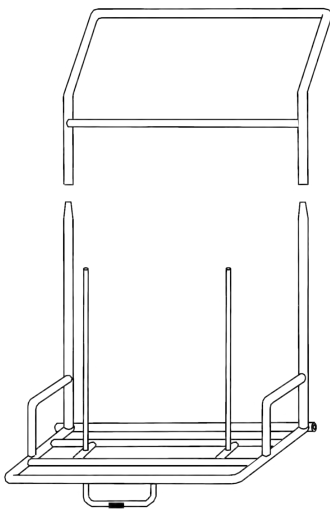

Figure 2

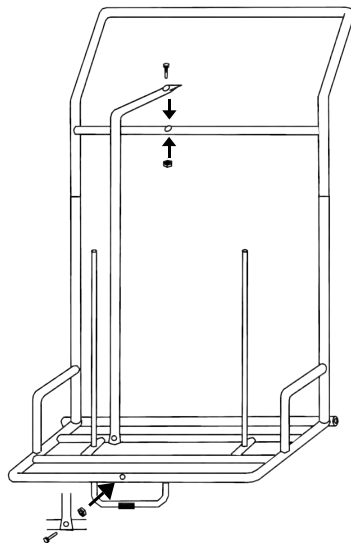
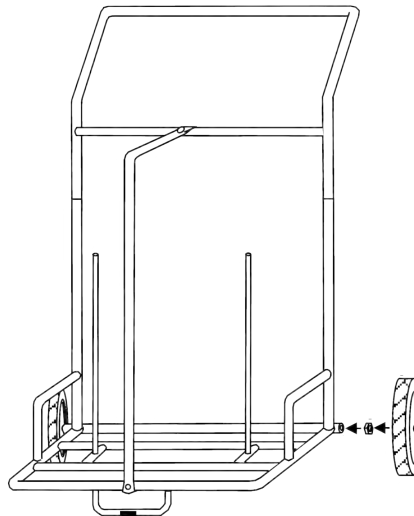
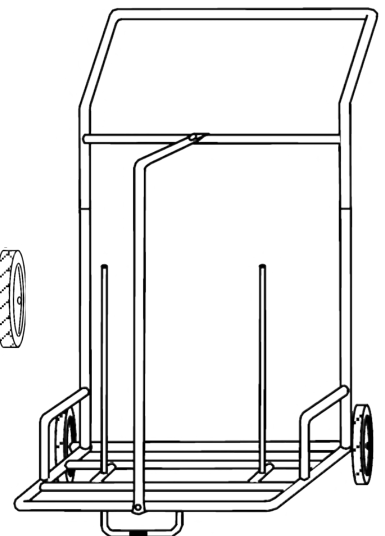

Figure 3



Complete



PARTS:

- 1 Crossbar Handle
- 1 Base
- 1 Center Bar
- 2 Center Bar Bolts (Small)
- 2 Center Bar Nuts (Small)
- 2 Wheels
- 2 Wheel Bolts (Large)
- 2 Wheel Washers
- 2 Wheel Nuts (Large)