



# DOUBLE-WIDE BALL CART

24BC

## Features:

- Constructed of 1" powder coated tubular steel
- Heavy-duty casters and rubberized wheels
- 40" height brings basketballs to hand level
- Holds 24 basketballs
- Storage shelf at the bottom
- White
- 42"L x 20"W x 44"H

## Parts:

- 1 Upright Side Panel A
- 1 Upright Side Panel B
- 3 Shelves
- 4 Swivel caster wheels
- 12 Screws
- 12 Bolts
- 24 Washers

## Instructions:

The rugged Champion Sports Double-Wide Ball Cart stores up to 24 basketballs at an easy-to-grab height.

1. Begin with side B of the cart by attaching the three shelves and securing each shelf with a screw, washer and bolt. Figure 1.
2. Attach side A of the cart to the three shelves already attached to side B and secure each shelf with a screw, washer and bolt. Figure 2.
3. Ensure all sections are secure with screws. Figure 3.
4. Secure the wheels in place. Turn the top spring of the wheel above the ball bearings clockwise until it becomes tight.



Balls Not Included

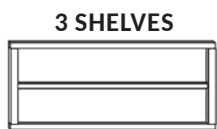
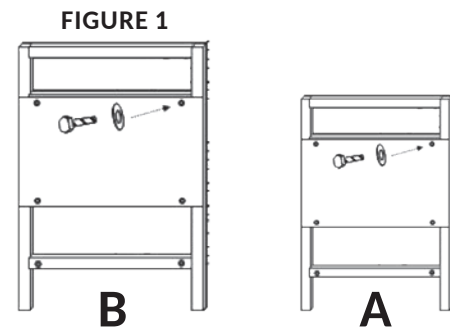

FIGURE 3

